

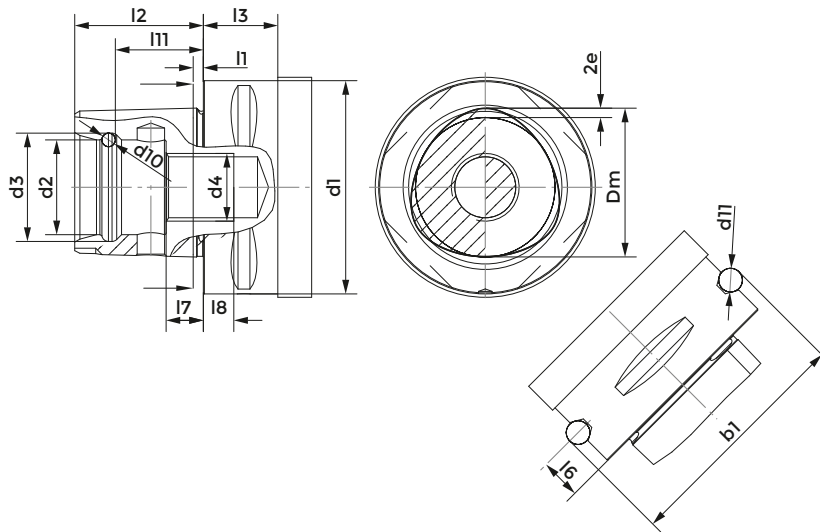

POLYGONAL TOOLHOLDERS AND TURNING TOOLS FOR TURNING

DIN ISO 26623-1

POLYGONAL SHANKS DATA SHEET



DIN ISO 26623-1

	C32	C40	C50	C63	C80	C80X	C100
b1	39	46	59,3	70,7	86	110	110
d1	32	40	50	63	80	100	100
d2	15	18	21	28	32	32	43
d3	16,5	20	24	32	38	38	50,5
d4	M12x1,5	M14x1,5	M16x1,5	M20x2	M20x2	M20x2	M24x2
d10	1,5	2	3	4	6	6	7,5
d11	5	5	7	7	7	10	10
Dm	22	28	35	44	55	55	72
e	0,7	0,9	1,12	1,4	2	2	2,8
l1	2,5	2,5	3	3	3	3	3
l2	19	24	30	38	48	48	60
l3	15	20	20	22	30	32	36
l6	6	8	10	12	12	16	16
l7	6	9	10	11	20	20	20
l8	6	6	7	9	0	0	10
l11	13,5	17,5	22	26	34	34	42,5

AXIAL BORING BAR HOLDER

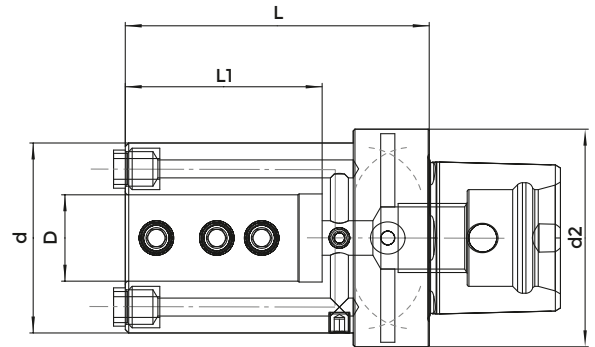

DIN ISO 26623-1

COD.	POLYGONAL	d	d2	D	L	L1	COOLANT NOOSE
							
C40H60D08E2	C40	33	40	8	60	37	833-001060
C40H65D10E2	C40	35	40	10	65	37	833-001060
C40H65D12E2	C40	36	40	12	65	40	833-001060
C40H70D16E2	C40	40	40	16	70	42	833-001060
C40H70D20E2	C40	45	40	20	70	42	833-001060
C50H70D08E2	C50	32	50	8	70	40	833-001070
C50H70D10E2	C50	35	50	10	70	37	833-001070
C50H70D12E2	C50	40	50	12	70	40	833-001070
C50H80D16E2	C50	45	50	16	80	50	833-001070
C50H80D20E2	C50	50	50	20	80	50	833-001070
C50H80D25E2	C50	55	50	25	80	50	833-001070
C63H80D08E2	C63	32	63	8	80	40	833-001060
C63H80D10E2	C63	38	63	10	80	45	833-001070
C63H80D12E2	C63	40	63	12	80	45	833-001070
C63H80D16E2	C63	45	63	16	80	50	833-001070
C63H80D20E2	C63	50	63	20	80	50	833-001070
C63H80D25E2	C63	57	63	25	88	57	833-001070
C63H95D32E2	C63	72	63	32	95	58	833-001070
C63H105D40E2	C63	80	63	40	105	72	833-001070
C80H85D20E2	C80	50	80	20	85	48	833-001070
C80H85D25E2	C80	55	80	25	85	48	833-001070
C80H95D32E2	C80	72	80	32	95	58	833-001080
C80H110D40E2	C80	80	80	40	110	73	833-001080

ACCESSORIES

p. 680



POLYGONAL FLANGE KIT

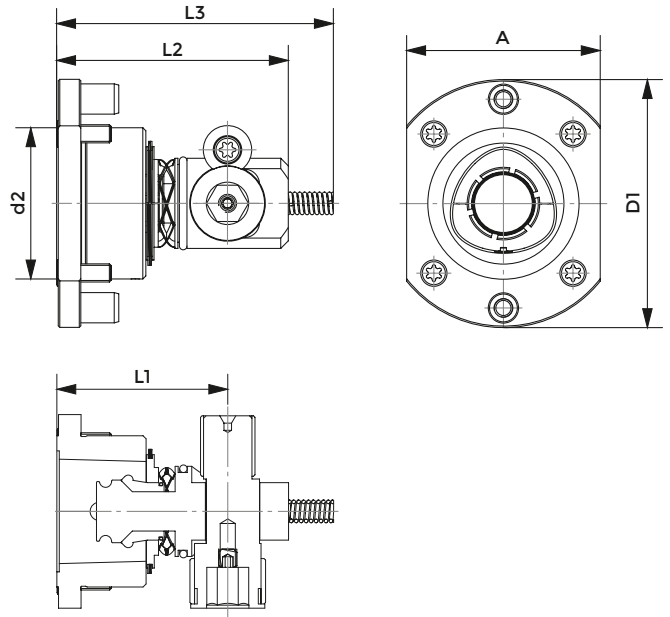

COD.	POLYGONAL	d2	d1	L1	L2	L3	A
CXC32-10	C32	32	54	40.5	55	67	38
CXC40-10	C40	40	67	48.5	65	80	48
CXC50-10	C50	50	82	56.5	75	91.5	64
CXC63-10	C63	63	105	74	93	112.5	84

INSTRUCTIONS TO CLAMP THE TOOLHOLDER TO THE MANUAL DRIVE (CAM) CLAMPING UNIT

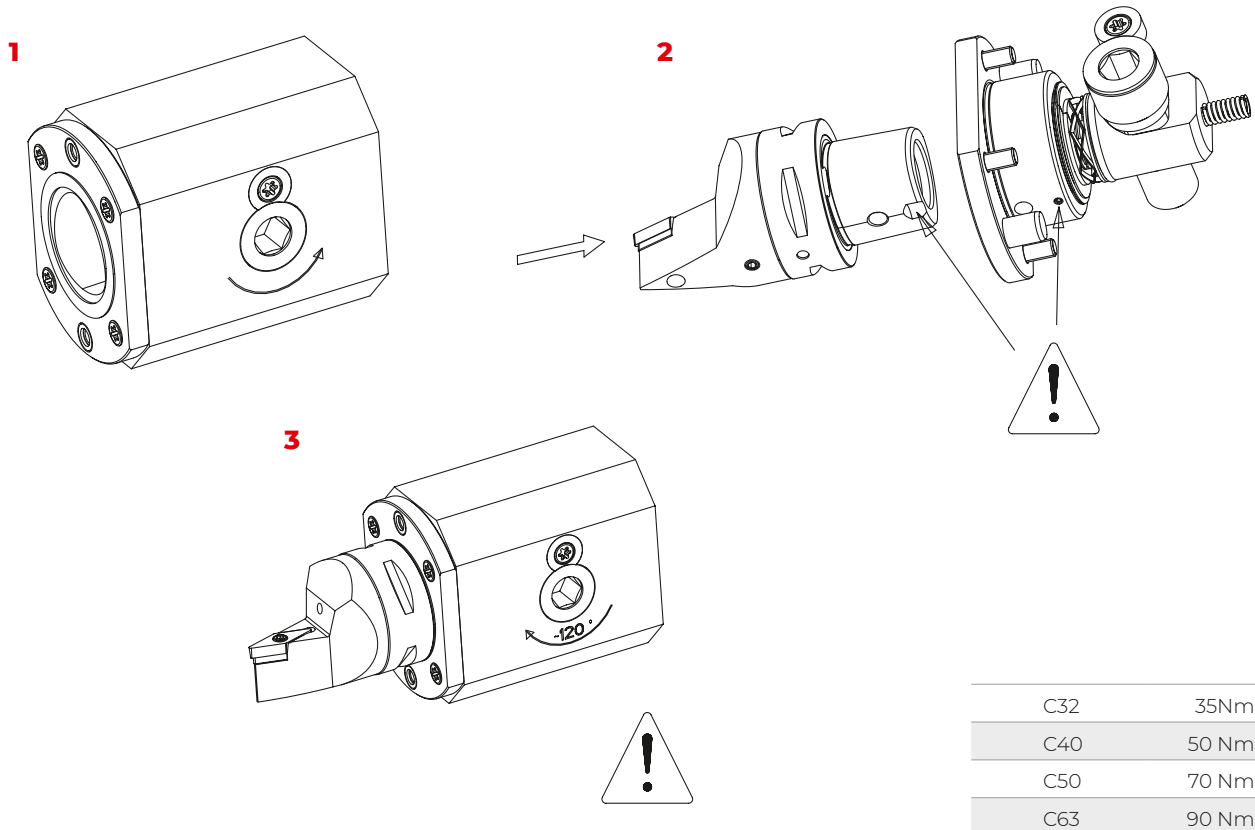

90° POLYGONAL TOOLHOLDER

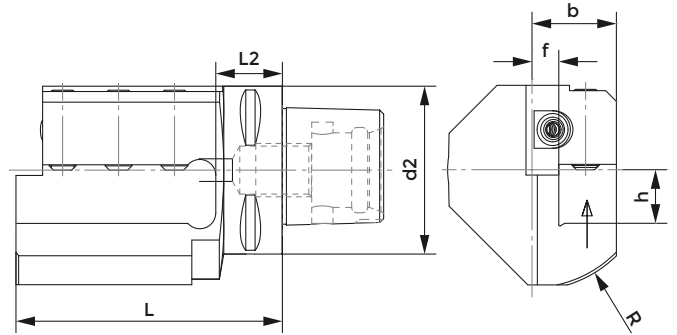

DIN ISO 26623-1

COD.	POLYGONAL	d2	L	L1	b	R	f	h
C50-AD2020R/L	C50	50	98	22	32	41,5	12	20
C63-AD2020R/L	C63	63	100	24	32	41,5	12	20
C63-AD2525R/L	C63	63	130	28	35	49	10	25
C63-AD3232R/L	C63	63	134	28	39	59	7	32

90° POLYGONAL TOOLHOLDER

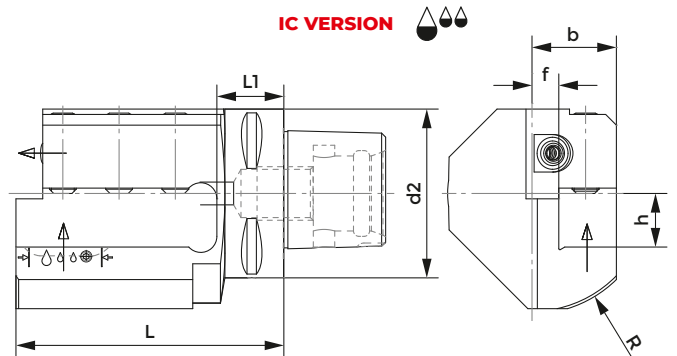

DIN ISO 26623-1

COD.	POLYGONAL	d2	L	L1	b	R	f	h
C63-AD2020R/L-IC	C63	63	100	24	32	41,5	12	20
C63-AD2525R/L-IC	C63	63	130	28	35	49	10	25
C63-AD3232R/L-IC	C63	63	134	28	39	59	7	32

PROTECTIVE CAP

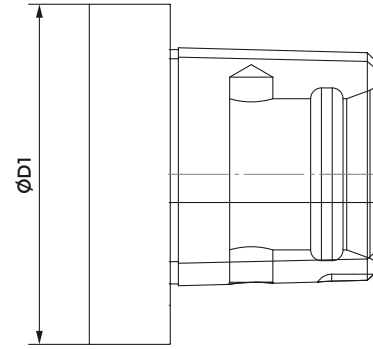

COD.	d
C40-TP	40
C50-TP	50
C63-TP	63
C80-TP	80

45° POLYGONAL TOOLHOLDER

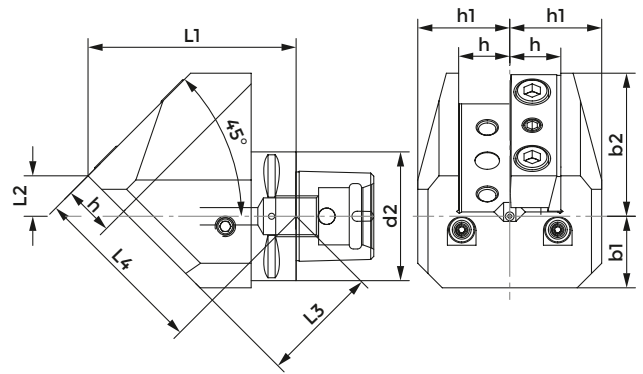

DIN ISO 26623-1

COD.	POLYGONAL	d2	b1	b2	h	h1	L1	L2	L3	L4
C63-ARD2525-45	C63	63	35	70	25	45	102	20	58	86

45° POLYGONAL TOOLHOLDER

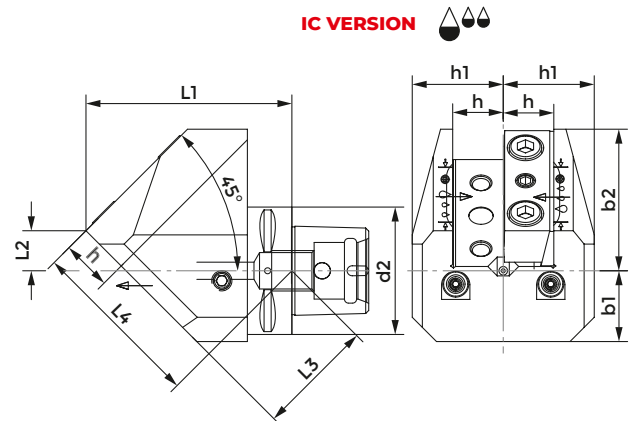

DIN ISO 26623-1

COD.	POLYGONAL	d2	b1	b2	h	h1	L1	L2	L3	L4
C63-ARD2525-45-IC	C63	63	35	70	25	45	102	20	58	86

45° POLYGONAL TOOLHOLDER

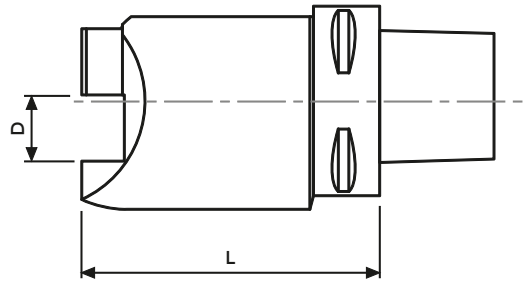

DIN ISO 26623-1

COD.	POLYGONAL	D	L
C63AR25R/L	C63	25	130

POLYGONAL RADIAL TOOLHOLDER

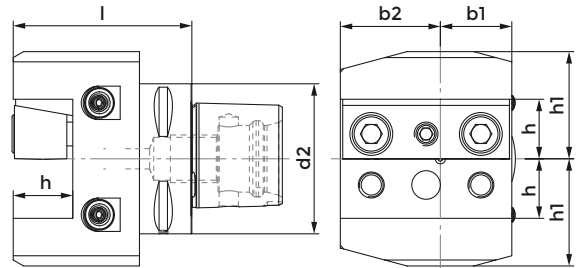

DIN ISO 26623-1

COD.	POLYGONAL	d2	b1	b2	h	h1	l
C63RD25R	C63	63	30	42	25	45	75

POLYGONAL AXIAL TOOLHOLDER

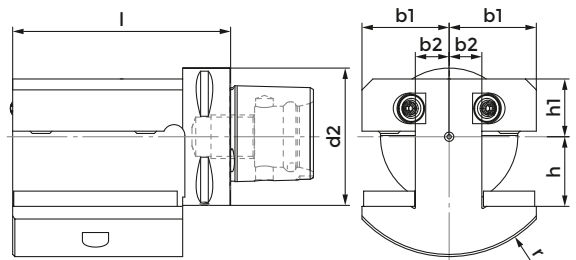

DIN ISO 26623-1

COD.	POLYGONAL	d2	b1	b2	h	h1	l	r
C63AX25/32	C63	63	40	15	25/32	26.5	110	55

POLYGONAL AXIAL TOOLHOLDER

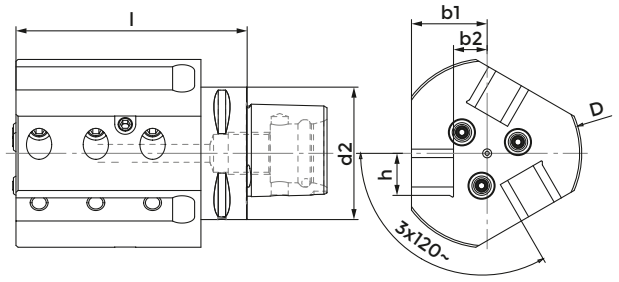

DIN ISO 26623-1

COD.	POLYGONAL	d2	b1	b2	h	l	D
C63AT20R	C63	63	36	16	20	110	90
C63AT20L	C63	63	36	16	20	110	90

POLYGONAL AXIAL TOOLHOLDER FOR CUT OFF TOOLS



IC VERSION 

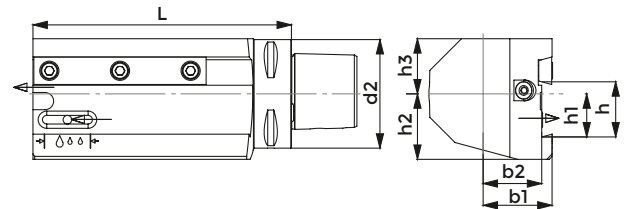

DIN ISO 26623-1

COD.	POLYGONAL	d2	b1	b2	h	h1	h2	h3	L
C50-SCAR26R/L-IC	C50	50	33	27	26	21,4	34	30	115
C63-SCAR26R/L-IC	C63	63	40	34	26	21,4	34	31,5	115
C63-SCAR32R/L-IC	C63	63	40	34	32	25	38	32	150

POLYGONAL AXIAL TOOLHOLDER

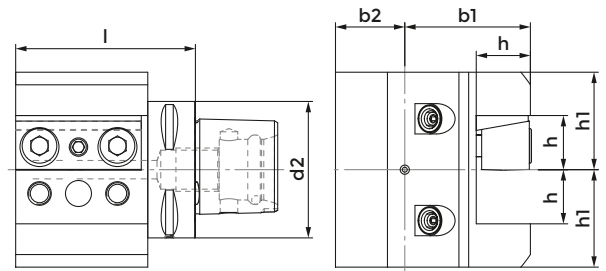

DIN ISO 26623-1

COD.	POLYGONAL	d2	b1	b2	h	h1	l
C63AD25R	C63	63	58	32	25	45	83

COOLANT SUPPLY UNIT

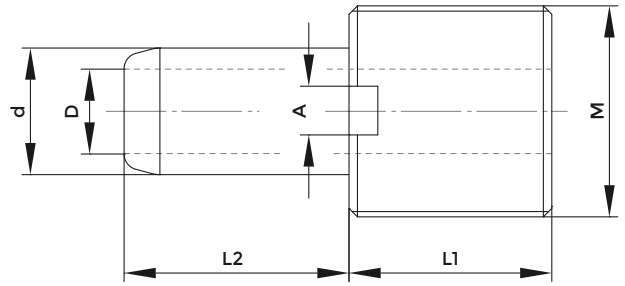

DIN ISO 26623-1

COD.	POLYGONAL	M	d	D	L1	L2	A
832-016080	C40	M14x1,5	6	4	12	13,5	3
832-016090	C50	M16x1,5	7	5	14	14,4	3
832-016100	C63	M20x2	8	6	15	15,7	3
832-016110	C80	M20x2	10	8	15	16,6	3

KEY FOR COOLANT SUPPLY UNIT

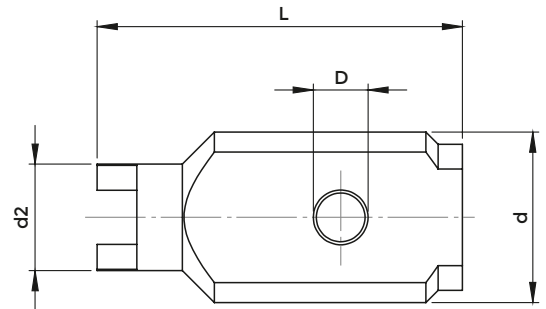

DIN ISO 26623-1

COD.	POLYGONAL	d	d2	D	L
816-204026	C50	42	26	10,5	90
816-204027	C63	63	32	10,5	100

TOOLHOLDER WITH SQUARE SHANK AND WITH POLYGONAL INTERFACE

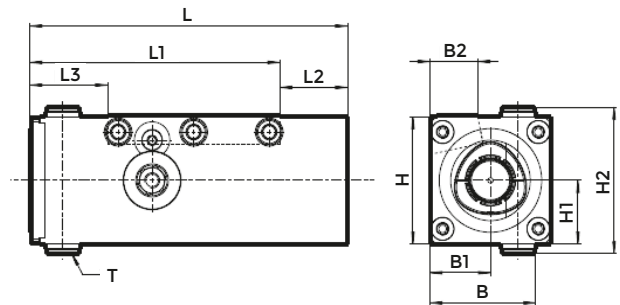

DIN ISO 26623-1

COD.	MISURA	L	L1	L2	L3	B	B1	B2	H	H1	H2	T
Q50L125C40R/L	C40	125	100	25	31	42	24	19	50	25	57,5	G 1/8

EXTERNAL TURNING TOOLS

DCM

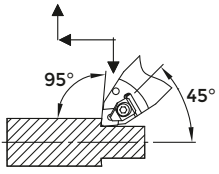

p. 293

SCM

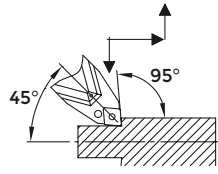

p. 297

SDJ

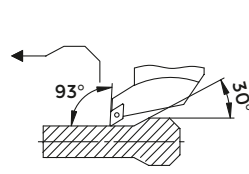

p. 296

DDM

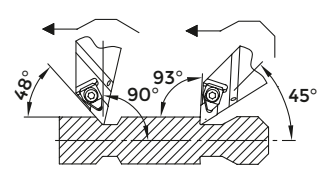

p. 293

SVM

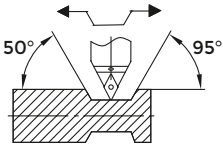

p. 298

SVJ

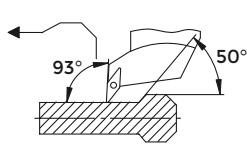

p. 297

PCL

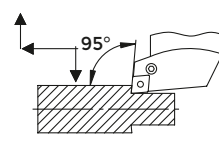

p. 294

DCL

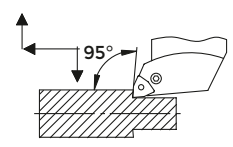

p. 292

PWL

p. 295

DWL

p. 292

THE

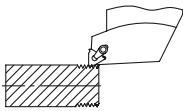

p. 298

PDJ

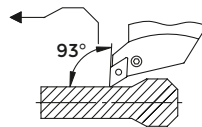

p. 294

SCL

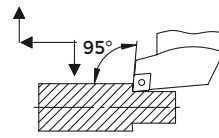

p. 295

SVH

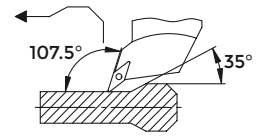

p. 296

INTERNAL TURNING TOOLS

PCL

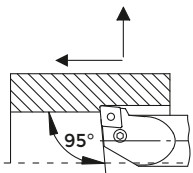

p. 299

PWL

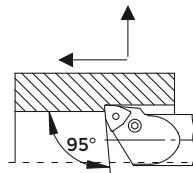

p. 299

SDU

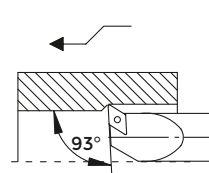

p. 301

THE

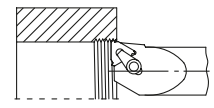

p. 302

SCL

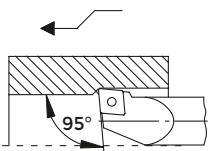

p. 300



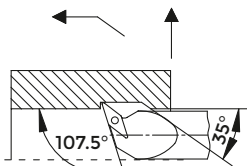















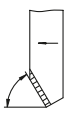
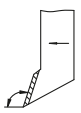
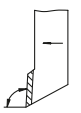
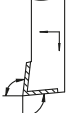
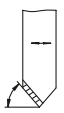

SVQ

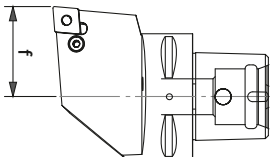
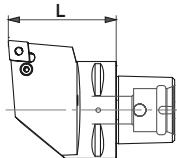

p. 302

**IDENTIFICATION OF ISO 26623-1
POLYGONAL EXTERNAL TURNING TOOLS**

Coding example C 50 S C L C L 35 060 12

C	Type of holder	DIN ISO 26623-1														
50	Holder size		40 - Ø40	50 - Ø50		63 - Ø63										
S	Clamping system		D		P											
C	Insert Shape		C		D		S		T		V		W			
L	Shape of turning tools	60		E	107.5		H	93		J	95		L	50		M
C	Clearance angle		B					C					N			
L	Feeding direction				L					R					N	
35	"f" dimension															
060	"l" dimension															
12	Insert cutting edge length				C - D - E - M - V		S		T					W		



















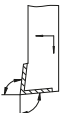

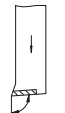
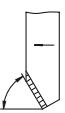

TURNING MODULAR SYSTEM

- Adopting the famous DIN ISO 26623-1, in the several versions, and maintaining an interchangeability with the attacks for working centers, KINTEK offers the possibility to reduce, drastically, the times of set-up.
- Maximum rapidity in the tool change
- Great rigidity thanks to the big support surface

- The same cutting position
- Reduction of the vibrations
- Precision of interchangeability
- Optimal repeatability of positioning to the change tool: maximum error +/- 0,002 mm

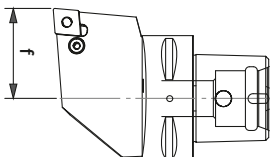
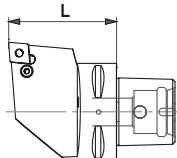
**IDENTIFICATION OF ISO 26623-1 POLYGONAL
INTERNAL TURNING TOOLS**



Coding example C 50 S C L C L 22 110 12

C	Type of holder	DIN ISO 26623-1				
50	Holder size	 40 - Ø40	50 - Ø50		63 - Ø63	
S	Clamping system	P 		S 		
C	Insert Shape	 C	 D	 T	 V	 W
L	Shape of turning tools	95  L	15  Q	93  U	60  E	
C	Clearance angle	 B	 C		 N	 P
L	Feeding direction	 L		 R	 N	
35	"f" dimension					
060	"l" dimension					
12	Insert cutting edge length	 C - D - V	 T		 W	

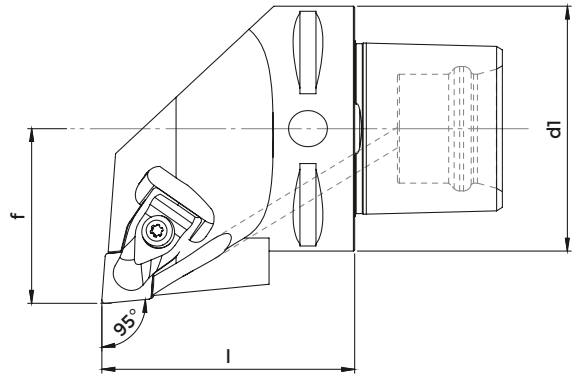
ISO 26623-1 POLYGONAL EXTERNAL TURNING TOOLS



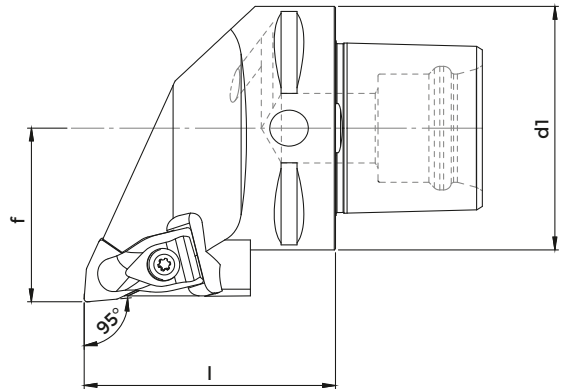

DCLN

COD.	DESCRIPTION	POLYGONAL	d1	l	f	INSERT	BRACKET	SUPPORT PAD	SCREW
									
C50DCLNL3506012	UTENSILE C50-DCLNL12	C50	50	60	35	CN..1204..	831-003070	843-022061	811-276013
C50DCLNR3506012	UTENSILE C50-DCLNR12	C50	50	60	35	CN..1204..	831-003070	843-022061	811-276013
C63DCLNL4506512	UTENSILE C63-DCLNL12	C63	63	65	45	CN..1204..	831-003070	843-022061	811-276013
C63DCLNR4506512	UTENSILE C63-DCLNR12	C63	63	65	45	CN..1204..	831-003070	843-022061	811-276013
C63DCLNL4506516	UTENSILE C63-DCLNL16	C63	63	65	45	CN..1604..	831-003080	843-021221	811-296004
C63DCLNR4506516	UTENSILE C63-DCLNR16	C63	63	65	45	CN..1604..	831-003080	843-021221	811-296004





DWLN

COD.	DESCRIPTION	POLYGONAL	d1	l	f	INSERT	BRACKET	SUPPORT PAD	SCREW
									
C50DWLNL3506008	UTENSILE C50-DWLNL08	C50	50	60	35	WN..0804..	831-003070	843-081131	811-276013
C50DWLNR3506008	UTENSILE C50-DWLNR08	C50	50	60	35	WN..0804..	831-003070	843-081131	811-276013
C63DWLNL4506508	UTENSILE C63-DWLNL08	C63	63	65	45	WN..0804..	831-003070	843-081131	811-276013
C63DWLNR4506508	UTENSILE C63-DWLNR08	C63	63	65	45	WN..0804..	831-003070	843-081131	811-276013

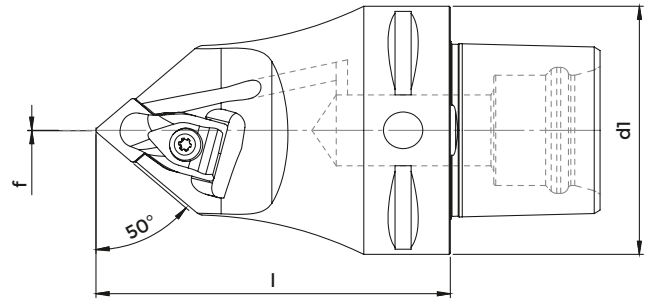
ISO 26623-1 POLYGONAL EXTERNAL TURNING TOOLS



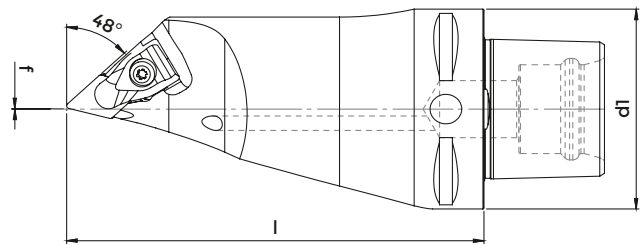

DCMN

COD.	DESCRIPTION	POLYGONAL	d1	l	f	INSERT	BRACKET	SUPPORT PAD	SCREW
									
C63DCMNN0009012	UTENSILE C63-DCMNN12	C63	63	90	0	CN..1204..	831-003070	843-022061	811-276013
C63DCMNN0011512	UTENSILE C63-DCMNN12	C63	63	115	0	CN..1204..	831-003070	843-022061	811-276013





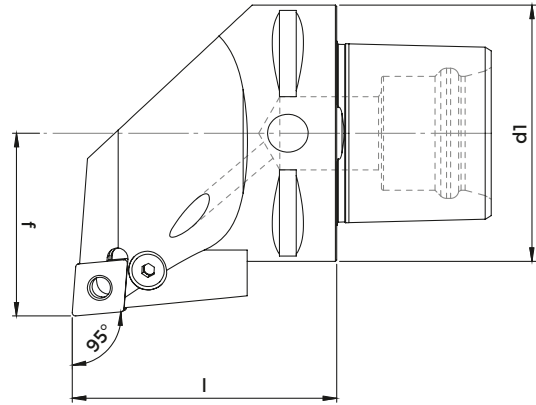

DDMN

COD.	DESCRIPTION	POLYGONAL	d1	l	f	INSERT	BRACKET	SUPPORT PAD	SCREW
									
C63DDMNL0013015	UTENSILE C63-DDMNL15	C63	63	130	0	DN..1506..	831-003070	843-031241	811-276013

ISO 26623-1 POLYGONAL EXTERNAL TURNING TOOLS





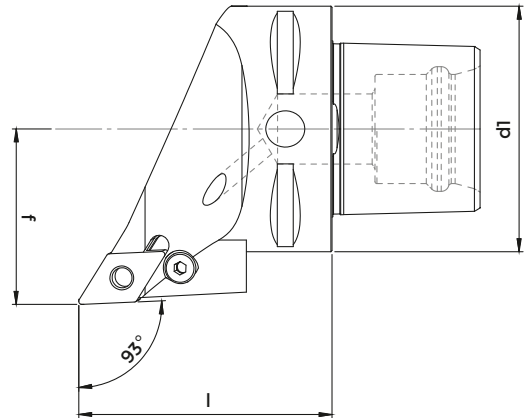

PCLN

COD.	DESCRIPTION	POLYGONAL	d1	l	f	INSERT	LEVER	SCREW	SUPPORT PAD	SPRING
										
C40PCLNL2705012	UTENSILE C40-PCLNL12	C40	40	50	27	CN..1204..	831-001540	811-301153	843-022061	815-321400
C40PCLNR2705012	UTENSILE C40-PCLNR12	C40	40	50	27	CN..1204..	831-001540	811-301153	843-022061	815-321400
C50PCLNL3506012	UTENSILE C50-PCLNL12	C50	50	60	35	CN..1204..	831-001540	811-301153	843-022061	815-321400
C50PCLNR3506012	UTENSILE C50-PCLNR12	C50	50	60	35	CN..1204..	831-001540	811-301153	843-022061	815-321400
C63PCLNL4506512	UTENSILE C63-PCLNL12	C63	63	65	45	CN..1204..	831-001540	811-301153	843-022061	815-321400
C63PCLNR4506512	UTENSILE C63-PCLNR12	C63	63	65	45	CN..1204..	831-001540	811-301153	843-022061	815-321400
C63PCLNL4506516	UTENSILE C63-PCLNL16	C63	63	65	45	CN..1604..	831-001550	811-301154	843-021221	815-321410
C63PCLNR4506516	UTENSILE C63-PCLNR16	C63	63	65	45	CN..1604..	831-001550	811-301154	843-021221	815-321410





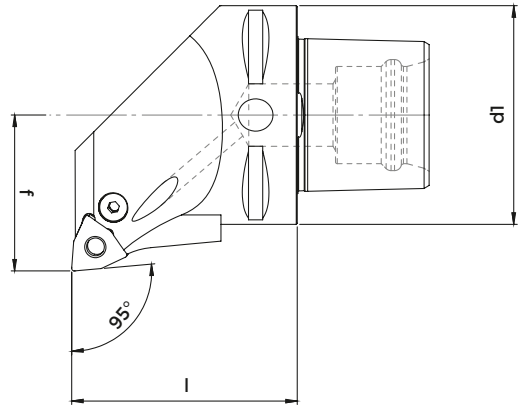

PDJN

COD.	DESCRIPTION	POLYGONAL	d1	l	f	INSERT	LEVER	SCREW	SUPPORT PAD	SPRING
										
C50PDJNL3506015	UTENSILE C50-PDJNL15	C50	50	60	35	DN..1506..	831-001560	811-301155	843-031241	815-321400
C50PDJNR3506015	UTENSILE C50-PDJNR15	C50	50	60	35	DN..1506..	831-001560	811-301155	843-031241	815-321400
C63PDJNL4506515	UTENSILE C63-PDJNL15	C63	63	65	45	DN..1506..	831-001560	811-301155	843-031241	815-321400
C63PDJNR4506515	UTENSILE C63-PDJNR15	C63	63	65	45	DN..1506..	831-001560	811-301155	843-031241	815-321400

ISO 26623-1 POLYGONAL EXTERNAL TURNING TOOLS



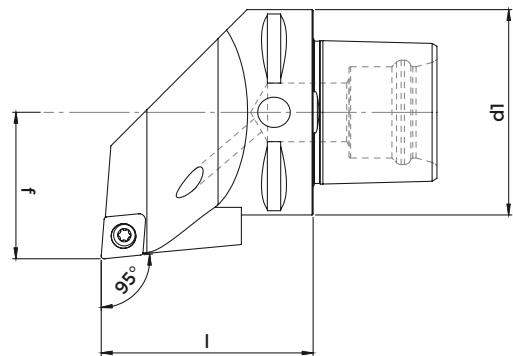

PWLN

COD.	DESCRIPTION	POLYGONAL	d1	l	f	INSERT	LEVER	SCREW	SUPPORT PAD	SPRING
C40PWLNL2705008	UTENSILE C40-PWLNL08	C40	40	50	27	WN..0804..				
C40PWLNR2705008	UTENSILE C40-PWLNR08	C40	40	50	27	WN..0804..	831-001540	811-301153	843-081131	815-321400
C50PWLNL3506008	UTENSILE C50-PWLNL08	C50	50	60	35	WN..0804..	831-001540	811-301153	843-081131	815-321400
C50PWLNR3506008	UTENSILE C50-PWLNR08	C50	50	60	35	WN..0804..	831-001540	811-301153	843-081131	815-321400
C63PWLNL4506508	UTENSILE C63-PWLNL08	C63	63	65	45	WN..0804..	831-001540	811-301153	843-081131	815-321400
C63PWLNR4506508	UTENSILE C63-PWLNR08	C63	63	65	45	WN..0804..	831-001540	811-301153	843-081131	815-321400





SCLC

COD.	DESCRIPTION	POLYGONAL	d1	l	f	INSERT	SUPPORT PAD	BUSH	SCREW
C40SCLCL2705012	UTENSILE C40-SCLCL12	C40	40	50	27	CC..1204..			
C40SCLCR2705012	UTENSILE C40-SCLCR12	C40	40	50	27	CC..1204..	843-022051	811-301156	811-266006
C50SCLCL3506012	UTENSILE C50-SCLCL12	C50	50	60	35	CC..1204..	843-022051	811-301156	811-266006
C50SCLCR3506012	UTENSILE C50-SCLCR12	C50	50	60	35	CC..1204..	843-022051	811-301156	811-266006
C63SCLCL4506512	UTENSILE C63-SCLCL12	C63	63	65	45	CC..1204..	843-022051	811-301156	811-266006
C63SCLCR4506512	UTENSILE C63-SCLCR12	C63	63	65	45	CC..1204..	843-022051	811-301156	811-266006

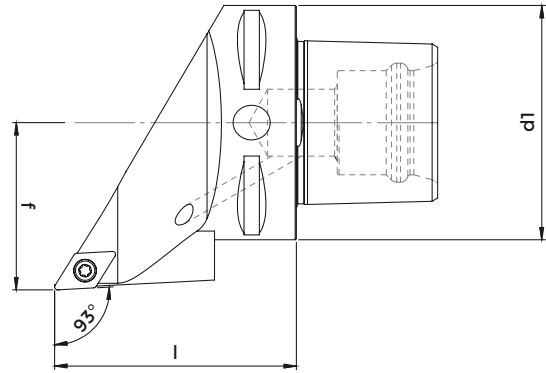
ISO 26623-1 POLYGONAL EXTERNAL TURNING TOOLS



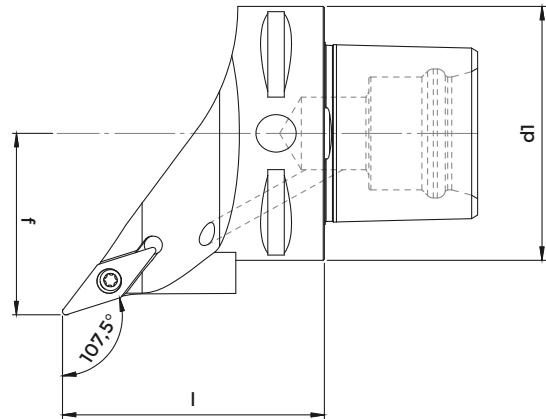

SDJC

COD.	DESCRIPTION	POLYGONAL	d1	l	f	INSERT	SUPPORT PAD	BUSH	SCREW
									
C40SDJCL2705011	UTENSILE C40-SDJCL11	C40	40	50	27	DC..11T3..	843-032031	811-301157	811-246021
C40SDJCR2705011	UTENSILE C40-SDJCR11	C40	40	50	27	DC..11T3..	843-032031	811-301157	811-246021
C50SDJCL3506011	UTENSILE C50-SDJCL11	C50	50	60	35	DC..11T3..	843-032031	811-301157	811-246021
C50SDJCR3506011	UTENSILE C50-SDJCR11	C50	50	60	35	DC..11T3..	843-032031	811-301157	811-246021
C63SDJCL4506511	UTENSILE C63-SDJCL11	C63	63	65	45	DC..11T3..	843-032031	811-301157	811-246021
C63SDJCR4506511	UTENSILE C63-SDJCR11	C63	63	65	45	DC..11T3..	843-032031	811-301157	811-246021





SVHB

COD.	DESCRIPTION	POLYGONAL	d1	l	f	INSERT	SUPPORT PAD	BUSH	SCREW
									
C40SVHBL2705016	UTENSILE C40-SVHBL16	C40	40	50	27	VB..1604..	843-062071	811-301157	811-246021
C40SVHBR2705016	UTENSILE C40-SVHBR16	C40	40	50	27	VB..1604..	843-062071	811-301157	811-246021
C50SVHBL3506016	UTENSILE C50-SVHBL16	C50	50	60	35	VB..1604..	843-062071	811-301157	811-246021
C50SVHBR3506016	UTENSILE C50-SVHBR16	C50	50	60	35	VB..1604..	843-062071	811-301157	811-246021
C63SVHBL4506516	UTENSILE C63-SVHBL16	C63	63	65	45	VB..1604..	843-062071	811-301157	811-246021
C63SVHBR4506516	UTENSILE C63-SVHBR16	C63	63	65	45	VB..1604..	843-062071	811-301157	811-246021

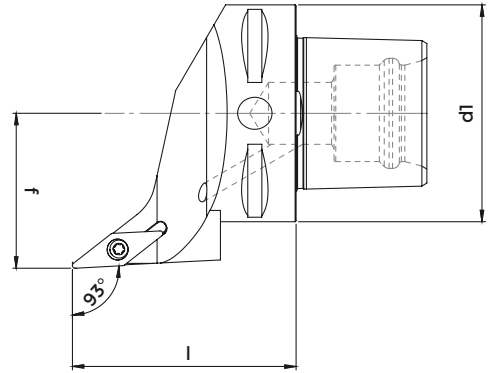
ISO 26623-1 POLYGONAL EXTERNAL TURNING TOOLS



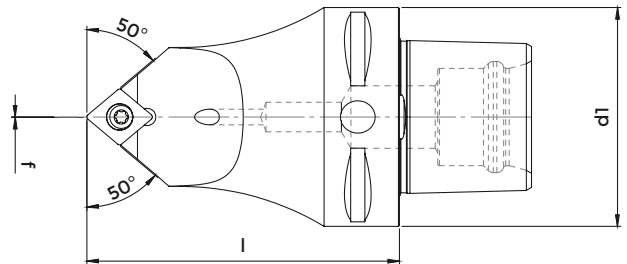

SVJB

COD.	DESCRIPTION	POLYGONAL	d1	l	f	INSERT	SUPPORT PAD	BUSH	SCREW
									
C40SVJBL2705016	UTENSILE C40-SVJBL16	C40	40	50	27	VB..1604..	843-062071	811-301157	811-246021
C40SVJBR2705016	UTENSILE C40-SVJBR16	C40	40	50	27	VB..1604..	843-062071	811-301157	811-246021
C50SVJBL3506016	UTENSILE C50-SVJBL16	C50	50	60	35	VB..1604..	843-062071	811-301157	811-246021
C50SVJBR3506016	UTENSILE C50-SVJBR16	C50	50	60	35	VB..1604..	843-062071	811-301157	811-246021
C63SVJBL4506516	UTENSILE C63-SVJBL16	C63	63	65	45	VB..1604..	843-062071	811-301157	811-246021
C63SVJBR4506516	UTENSILE C63-SVJBR16	C63	63	65	45	VB..1604..	843-062071	811-301157	811-246021





SCMC

COD.	DESCRIPTION	POLYGONAL	d1	l	f	INSERT	SUPPORT PAD	BUSH	SCREW
									
C63SCMCN0009012	UTENSILE C63-SCMCN12	C63	63	90	0	CC..1204..	843-022051	811-301156	811-266006

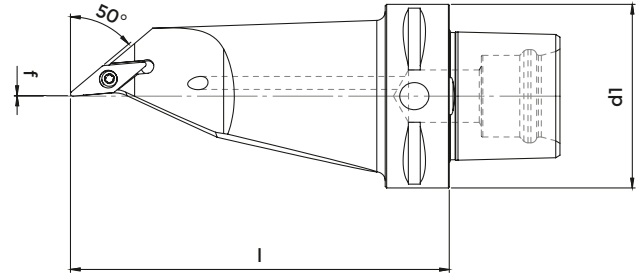
ISO 26623-1 POLYGONAL EXTERNAL TURNING TOOLS





SVMB

COD.	DESCRIPTION	POLYGONAL	d1	l	f	INSERT	SUPPORT PAD	BUSH	SCREW
C63SVMBL0013016	UTENSILE C63-SVMBL16	C63	63	130	0	VB..1604..			
							843-062071	811-301157	811-246021

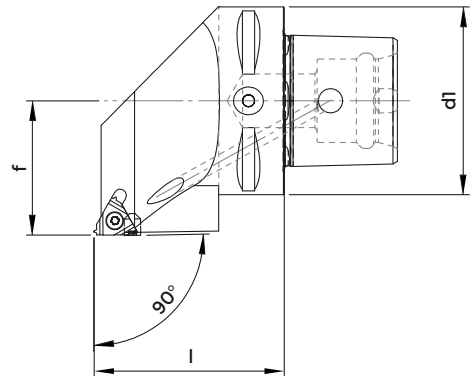
ISO 26623-1 POLYGONAL EXTERNAL THREADING TOOLS





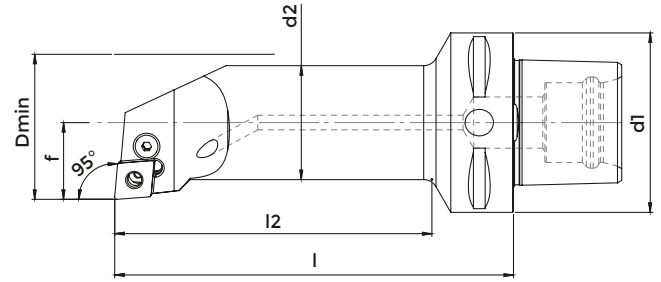

THE

COD.	DESCRIPTION	POLYGONAL	d1	l	f	INSERT	SUPPORT PAD	SCREW	SCREW
C40THEL2705016	UTENSILE C40-SEL16	C40	40	50	27	16EL...			
C40THER2705016	UTENSILE C40-SER16	C40	40	50	27	16ER...			
C50THEL3506016	UTENSILE C50-SEL16	C50	50	60	35	16EL...			
C50THER3506016	UTENSILE C50-SER16	C50	50	60	35	16ER...			
C63THEL4506516	UTENSILE C63-SEL16	C63	63	65	45	16EL...			
C63THER4506516	UTENSILE C63-SER16	C63	63	65	45	16ER...			

ISO 26623-1 POLYGONAL INTERNAL TURNING TOOLS





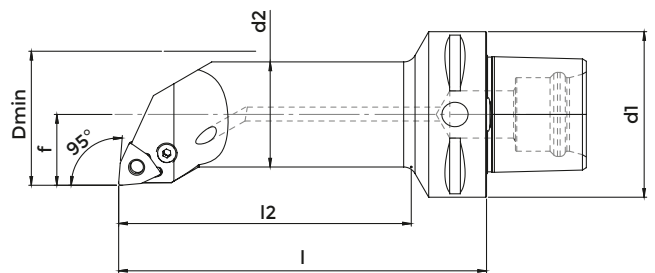

PCLN

COD.	DESCRIPTION	POLYGONAL	d1	d2	l	l2	f	Dmin	INSERT	LEVER	SCREW	SUPPORT PAD	SPRING
													
C40PCLNL2211012	UTENSILE C40-PCLNL12	C40	40	32	110	87	22	39	CN.1204..	831-001540	811-301153	843-022061	815-321400
C40PCLNR2211012	UTENSILE C40-PCLNR12	C40	40	32	110	87	22	39	CN.1204..	831-001540	811-301153	843-022061	815-321400
C50PCLNL2211012	UTENSILE C50-PCLNL12	C50	50	32	110	87	22	39	CN.1204..	831-001540	811-301153	843-022061	815-321400
C50PCLNR2211012	UTENSILE C50-PCLNR12	C50	50	32	110	87	22	39	CN.1204..	831-001540	811-301153	843-022061	815-321400
C63PCLNL2714012	UTENSILE C63-PCLNL12	C63	63	40	140	111	27	48	CN.1204..	831-001540	811-301153	843-022061	815-321400
C63PCLNR2714012	UTENSILE C63-PCLNR12	C63	63	40	140	111	27	48	CN.1204..	831-001540	811-301153	843-022061	815-321400





PWLN

COD.	DESCRIPTION	POLYGONAL	d1	d2	l	l2	f	Dmin	INSERT	LEVER	SCREW	SUPPORT PAD	SPRING
													
C40PWLNL2211008	UTENSILE C40-PWLNL08	C40	40	32	110	87	22	39	WN.0804..	831-001540	811-301153	843-081131	815-321400
C40PWLNR2211008	UTENSILE C40-PWLNR08	C40	40	32	110	87	22	39	WN.0804..	831-001540	811-301153	843-081131	815-321400
C50PWLNL2211008	UTENSILE C50-PWLNL08	C50	50	32	110	87	22	39	WN.0804..	831-001540	811-301153	843-081131	815-321400
C50PWLNR2211008	UTENSILE C50-PWLNR08	C50	50	32	110	87	22	39	WN.0804..	831-001540	811-301153	843-081131	815-321400
C63PWLNL2714008	UTENSILE C63-PWLNL08	C63	63	40	140	111	27	48	WN.0804..	831-001540	811-301153	843-081131	815-321400
C63PWLNR2714008	UTENSILE C63-PWLNR08	C63	63	40	140	111	27	48	WN.0804..	831-001540	811-301153	843-081131	815-321400

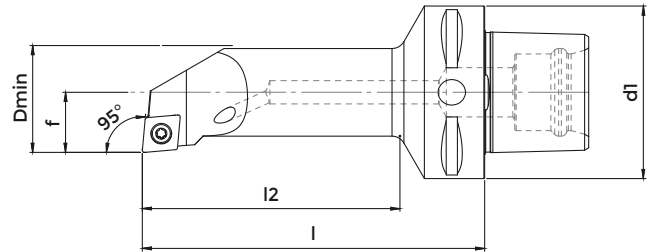
ISO 26623-1 POLYGONAL INTERNAL TURNING TOOLS



SCLC

COD.	DESCRIPTION	POLYGONAL	d1	d2	l	l2	f	Dmin	INSERT	SUPPORT PAD	BUSH	SCREW
C40SCLCL1107009	UTENSILE C40-SCLCL09	C40	40	16	70	47	11	20	CC..09T3..			
C40SCLCR1107009	UTENSILE C40-SCLCR09	C40	40	16	70	47	11	20	CC..09T3..	-	-	811-256031
C40SCLCL1308009	UTENSILE C40-SCLCL09	C40	40	20	80	58	13	25	CC..09T3..	-	-	811-256031
C40SCLCR1308009	UTENSILE C40-SCLCR09	C40	40	20	80	58	13	25	CC..09T3..	-	-	811-256031
C40SCLCL1709012	UTENSILE C40-SCLCL12	C40	40	25	90	68	17	30	CC..1204..	-	-	811-266005
C40SCLCR1709012	UTENSILE C40-SCLCR12	C40	40	25	90	68	17	30	CC..1204..	-	-	811-266005
C40SCLCL2211012	UTENSILE C40-SCLCL12	C40	40	32	110	87	22	39	CC..1204..	843-022051	811-301156	811-266006
C40SCLCR2211012	UTENSILE C40-SCLCR12	C40	40	32	110	87	22	39	CC..1204..	843-022051	811-301156	811-266006
C50SCLCL1709012	UTENSILE C50-SCLCL12	C50	50	25	90	68	17	30	CC..1204..	-	-	811-266005
C50SCLCR1709012	UTENSILE C50-SCLCR12	C50	50	25	90	68	17	30	CC..1204..	-	-	811-266005
C50SCLCL2211012	UTENSILE C50-SCLCL12	C50	50	32	110	87	22	39	CC..1204..	843-022051	811-301156	811-266006
C50SCLCR2211012	UTENSILE C50-SCLCR12	C50	50	32	110	87	22	39	CC..1204..	843-022051	811-301156	811-266006
C63SCLCL2212512	UTENSILE C63-SCLCL12	C63	63	32	125	102	22	39	CC..1204..	843-022051	811-301156	811-266006
C63SCLCR2212512	UTENSILE C63-SCLCR12	C63	63	32	125	102	22	39	CC..1204..	843-022051	811-301156	811-266006
C63SCLCL2216012	UTENSILE C63-SCLCL12	C63	63	32	160	132	22	39	CC..1204..	843-022051	811-301156	811-266006
C63SCLCR2216012	UTENSILE C63-SCLCR12	C63	63	32	160	132	22	39	CC..1204..	843-022051	811-301156	811-266006
C63SCLCL2714012	UTENSILE C63-SCLCL12	C63	63	40	140	111	27	48	CC..1204..	843-022051	811-301156	811-266006
C63SCLCR2714012	UTENSILE C63-SCLCR12	C63	63	40	140	111	27	48	CC..1204..	843-022051	811-301156	811-266006
C63SCLCL2718012	UTENSILE C63-SCLCL12	C63	63	40	180	151	27	48	CC..1204..	843-022051	811-301156	811-266006
C63SCLCR2718012	UTENSILE C63-SCLCR12	C63	63	40	180	151	27	48	CC..1204..	843-022051	811-301156	811-266006

ISO 26623-1 POLYGONAL INTERNAL TURNING TOOLS

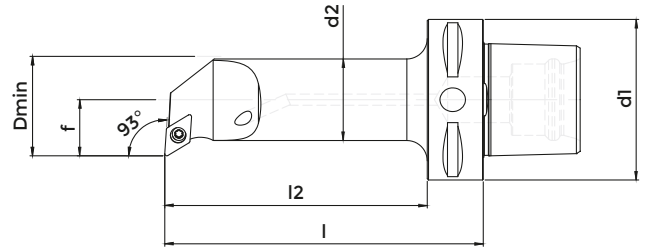



SDUC

COD.	DESCRIPTION	POLYGONAL	d1	d2	l	l2	f	Dmin	INSERT	SUPPORT PAD	BUSH	SCREW
C40SDUCL1107007	UTENSILE C40-SDUCL07	C40	40	16	70	47	11	20	DC..0702..	-	-	811-226020
C40SDUCR1107007	UTENSILE C40-SDUCR07	C40	40	16	70	47	11	20	DC..0702..	-	-	811-226020
C40SDUCL1308011	UTENSILE C40-SDUCL11	C40	40	20	80	58	13	25	DC..11T3..	-	-	811-256031
C40SDUCR1308011	UTENSILE C40-SDUCR11	C40	40	20	80	58	13	25	DC..11T3..	-	-	811-256031
C40SDUCL1709011	UTENSILE C40-SDUCL11	C40	40	25	90	68	17	30	DC..11T3..	-	-	811-256032
C40SDUCR1709011	UTENSILE C40-SDUCR11	C40	40	25	90	68	17	30	DC..11T3..	-	-	811-256032
C40SDUCL2211011	UTENSILE C40-SDUCL11	C40	40	32	110	87	22	39	DC..11T3..	843-032031	811-301157	811-246021
C40SDUCR2211011	UTENSILE C40-SDUCR11	C40	40	32	110	87	22	39	DC..11T3..	843-032031	811-301157	811-246021
C50SDUCL1709011	UTENSILE C50-SDUCL11	C50	50	25	90	68	17	30	DC..11T3..	-	-	811-256032
C50SDUCR1709011	UTENSILE C50-SDUCR11	C50	50	25	90	68	17	30	DC..11T3..	-	-	811-256032
C50SDUCL2211011	UTENSILE C50-SDUCL11	C50	50	32	110	110	22	87	DC..11T3..	843-032031	811-301157	811-246021
C50SDUCR2211011	UTENSILE C50-SDUCR11	C50	50	32	110	110	22	87	DC..11T3..	843-032031	811-301157	811-246021
C63SDUCL2212511	UTENSILE C63-SDUCL11	C63	63	32	125	102	22	39	DC..11T3..	843-032031	811-301157	811-246021
C63SDUCR2212511	UTENSILE C63-SDUCR11	C63	63	32	125	102	22	39	DC..11T3..	843-032031	811-301157	811-246021
C63SDUCL2216011	UTENSILE C63-SDUCL11	C63	63	32	160	132	22	39	DC..11T3..	843-032031	811-301157	811-246021
C63SDUCR2216011	UTENSILE C63-SDUCR11	C63	63	32	160	132	22	39	DC..11T3..	843-032031	811-301157	811-246021
C63SDUCL2714011	UTENSILE C63-SDUCL11	C63	63	40	140	111	27	48	DC..11T3..	843-032031	811-301157	811-246021
C63SDUCR2714011	UTENSILE C63-SDUCR11	C63	63	40	140	111	27	48	DC..11T3..	843-032031	811-301157	811-246021
C63SDUCL2718011	UTENSILE C63-SDUCL11	C63	63	40	180	151	27	48	DC..11T3..	843-032031	811-301157	811-246021
C63SDUCR2718011	UTENSILE C63-SDUCR11	C63	63	40	180	151	27	48	DC..11T3..	843-032031	811-301157	811-246021

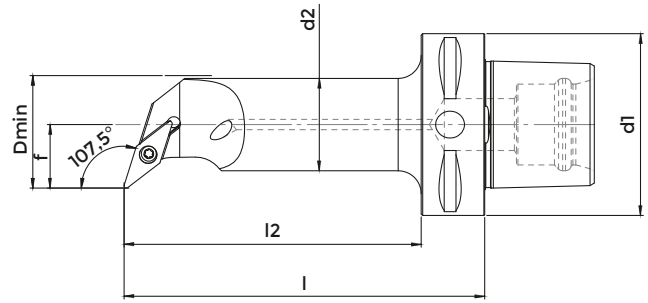
ISO 26623-1 POLYGONAL INTERNAL TURNING TOOLS





SVQB

COD.	DESCRIPTION	POLYGONAL	d1	d2	l	l2	f	Dmin	INSERT	SUPPORT PAD	BUSH	SCREW
												
C50SVQBL1709016	UTENSILE C50-SVQBL16	C50	50	25	90	65	17	30	VB.1604..	-	-	811-246020
C50SVQBR1709016	UTENSILE C50-SVQBR16	C50	50	25	90	65	17	30	VB.1604..	-	-	811-246020
C63SVQBL2212516	UTENSILE C63-SVQBL16	C63	63	32	125	95	22	39	VB.1604..	843-062071	811-301157	811-246021
C63SVQBR2212516	UTENSILE C63-SVQBR16	C63	63	32	125	95	22	39	VB.1604..	843-062071	811-301157	811-246021
C63SVQBL2718016	UTENSILE C63-SVQBL16	C63	63	40	180	150	27	48	VB.1604..	843-062071	811-301157	811-246021
C63SVQBR2718016	UTENSILE C63-SVQBR16	C63	63	40	180	150	27	48	VB.1604..	843-062071	811-301157	811-246021

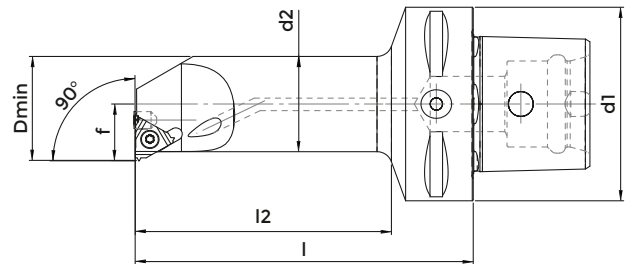
ISO 26623-1 POLYGONAL INTERNAL THREADING TOOLS



THE

COD.	DESCRIPTION	POLYGONAL	d1	d2	l	l2	f	Dmin	INSERT	SUPPORT PAD	SCREW	SCREW
												
C40THEL1709016	UTENSILE C40-ANL16	C40	40	25	90	65	17	32	16IL...	843-092261	811-207002	811-207001
C40THER1709016	UTENSILE C40-ANR16	C40	40	25	90	65	17	32	16IR...	843-092271	811-207002	811-207001
C50THEL1709016	UTENSILE C50-ANL16	C50	50	25	90	65	17	32	16IL...	843-092261	811-207002	811-207001
C50THER1709016	UTENSILE C50-ANR16	C50	50	25	90	65	17	32	16IR...	843-092271	811-207002	811-207001
C63THEL2011016	UTENSILE C63-ANL16	C63	63	31	110	78	20	39	16IL...	843-092261	811-207002	811-207001
C63THER2011016	UTENSILE C63-ANR16	C63	63	31	110	78	20	39	16IR...	843-092271	811-207002	811-207001



READY, ALWAYS.